

PRECISION DIAL TEST INDICATORS

INSIZE PLUS
MADE IN EUROPE

- Meet DIN2270
- Ceramic bearing
- Two measuring directions
- Supplied with one clamp: diameter $\varnothing 8\text{mm}$
- Optional accessory: styli



2880-02

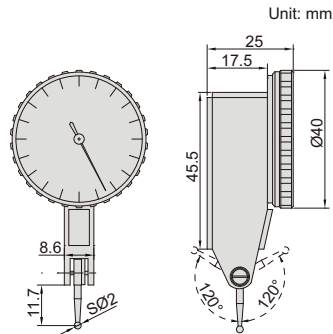

Unit: mm

**INSPECTION
CERTIFICATE**

ruby contact
point of **2880-02R**



clamp (included)

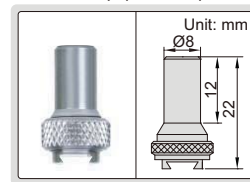

Code	Range	Graduation	Accuracy	Hysteresis	Dial reading	Remark
2880-02 *	0.2mm	0.002mm	4 μm	2 μm	0-100-0	anti magnetic carbide contact point
2880-02R *	0.2mm	0.002mm	4 μm	2 μm	0-100-0	ruby contact point

* Supplied with manufacturer inspection certificate